

PROJECT OPERATION MANUAL



ACCESS

Automated Community Communication and Earthquake Sensing System

Developed by:
Camden Galen, Adrian Mobley

In Collaboration with:

Table of Contents

<i>Introduction</i>	<i>3</i>
<i>⚠ Safety Warnings/Notices:</i>	<i>4</i>
<i>Getting Started</i>	<i>6</i>
<i>Schematic & Components Overview</i>	<i>8</i>
<i>Maintenance Routine</i>	<i>11</i>
<i>Troubleshooting</i>	<i>11</i>
<i>Arduino Code</i>	<i>12</i>
<i>3D Files</i>	<i>12</i>
<i>Bill of Materials</i>	<i>12</i>

Introduction

Manual Overview

This manual provides essential safety information, installation guidelines, and basic maintenance procedures for the outdoor earthquake detection unit. It is intended to help users understand the system's operation, ensure proper setup, and promote safe handling of the device in outdoor environments.

Project Overview

The Cascadia Subduction Zone is known to produce a major earthquake every 200 to 500 years. The last significant event occurred in 1700, meaning another could occur at any time. Coastal communities like Newport have taken steps to prepare, establishing evacuation zones and placing emergency supply caches with food, water, and shelter at strategic locations.

However, limited public awareness and access to these resources leave many residents and visitors vulnerable during a major earthquake or resulting tsunami.

To help address this gap, Sea Grant funded the development of a device designed to attach to community supply caches or assembly areas. Its purpose is to detect major seismic events and provide an immediate visual warning to guide people to safety while also enabling timely access to emergency supplies.

The system uses a programmable Adafruit ESP microcontroller paired with a 3-axis accelerometer to detect seismic activity. Upon detection, an LED beacon activates to direct the public, a solenoid unlocks a secured key box, and the microcontroller's Wi-Fi capability sends an alert email to staff. All components are housed in a durable, weatherproof enclosure for reliable outdoor operation.

Safety Warnings/Notices:

Electrical Safety

- This device operates on a 12V power supply. Improper handling may result in electric shock or damage to components.
- Ensure all wiring is secure and properly insulated to prevent accidental shorts or exposure to the elements.
- Use caution when working with the powered device—avoid contact with live terminals or exposed connections.

Outdoor Mounting & Weatherproofing

- The unit must be housed in a weatherproof enclosure (IP65 or higher) to prevent water ingress.
- All cable entry points should be sealed with rubber grommets or waterproof cable glands.
- Avoid mounting in direct sunlight or areas prone to flooding.
- Inspect the mounting hardware regularly to ensure the unit remains securely attached.

Fire Safety

- Do not install the device near flammable materials.
- Watch for signs of overheating, such as melted wiring or burnt odors, particularly in warmer environments.

Environmental Considerations

- The sensor is sensitive to vibrations. Avoid placing the unit near heavy equipment, air conditioning units, or roads with frequent traffic unrelated to seismic activity.
- Do not tamper with or relocate the unit without notifying the personnel responsible.

System Integrity

- Modifying or removing internal components may affect performance and reliability.
- Check periodically for wear, corrosion, or damage to the enclosure, cables, and connectors.

Emergency Notice

- This system is a detection aid and does not ensure safety. Always follow official emergency instructions during seismic events.
- Some environmental or technical conditions may lead to false alarms or missed detections.

Handling and Maintenance

- Handle with care—internal electronics can be sensitive to impact or static discharge.
- Certain maintenance procedures may require the device to be powered; use extra caution when performing such tasks.

Getting Started

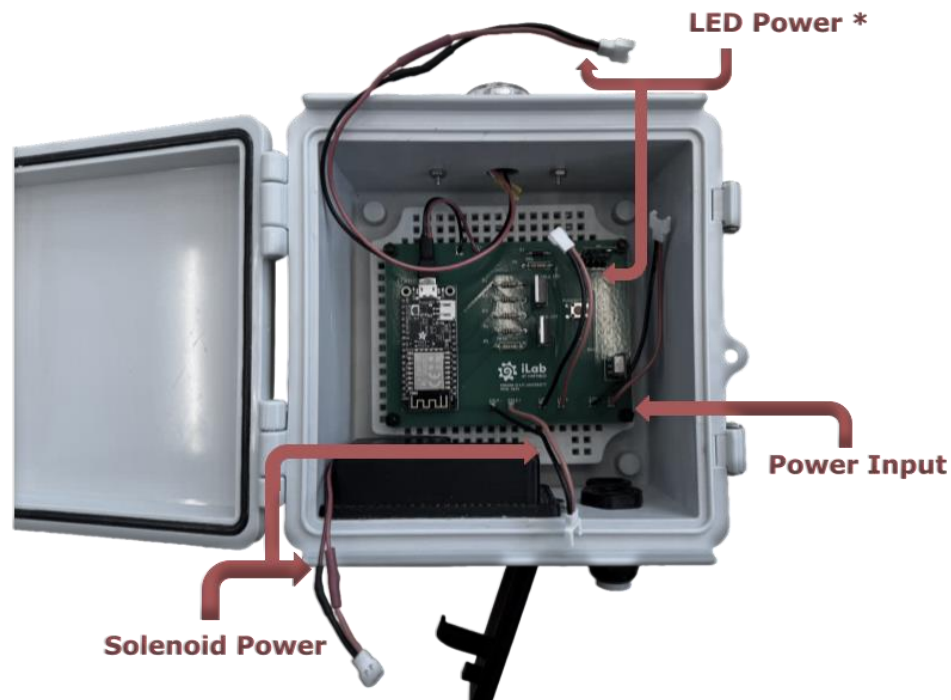

Figure 1. - Power Diagram

System Requirements:

1) 12 Volt Power Input

- a) Standard Duplex Receptacle required
- b) Refer to *Solar Module* section of manual for utilization of solar power

2) Level Mounting Surface – to ensure accuracy

- a) 3-axis accelerometer measures deviation from a level reference point.

3) Wi-Fi capabilities – if available; for alerts

- a) Typically, not utilized due to the deployment location and inaccessibility to a network.
 - i) Contact the iLab for more information regarding utilizing wi-fi capabilities

Board Setup Instructions:

- 1) Refer to Figure 1. labeling on the printed circuit board
- 2) Connect the 2-pin header labeled LED into the female pin header on the LED beacon
- 3) Connect the 2-pin header labeled SOLE, short for solenoid, into the female header coming out of the key box that is connected to the solenoid
- 4) Connect the 2-pin header labeled 12V into the female 2-pin header for the 12V wall power adapter

Initial Startup Instructions:

- 1) Ensure power connections are secure
- 2) Ensure mounting location isn't prone to heavy water coverage
- 3) Once mounted at level, the system should only require external power, see *System Requirements*

* Once complete, refer to [Maintenance Routine](#), follow the necessary steps to ensure full functionality.

Schematic & Components Overview

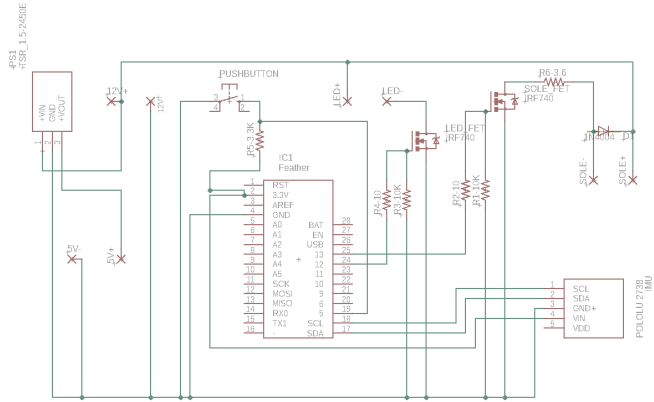

Figure 2. Circuit Schematic

- Figure 2. includes necessary information to diagnose any issues related to circuitry



Figure 3. Test Button

- Provides a quick and easy way to test the device to ensure proper functionality
 - o Will need to reset power or initiate power cycle to reengage the device



Figure 4. RST Button

- To reset the system press the black button labeled RST on the microcontroller OR power cycle the device by unplugging and plugging the wall power adapter.



Figure 4. Key Box

- 3D printed to provide a time and cost effective, weather resistant component
- Must spool string around the key/access code when you reload the system as the volume in the box is small. Ensure that there is no interference with the latch and solenoid as the box can jam easily. Double check the device is not jammed by giving it a small wiggle, if there is a small amount of movement up and down it is ready, if there is large resistance or no movement the box is likely jammed.
 - If the box is jammed, press and hold the PUSHBUTTON while pulling down gently on the key box door and it should open. Reload and ensure no interference with the latch and solenoid.



Figure 5. Logic Board

- This is the assembled printed circuit board which runs the whole device.
- Refer to [Schematics and Component Overview](#) Figure 2.



Figure 6. LED

- Has a long cable and a magnet on the back, perfect for flat metal surface mounting.



Figure 7. IMU Accelerometer

- Sensitive sensor that records the acceleration data. Its orientation is key in its data collecting as it refers to the earth for its coordinate system. If the device is not parallel with the earth the acceleration data could be skewed and result in a false trigger.

Maintenance Routine

Following the Cache Maintenance Schedule, run a maintenance routine to ensure the device is still working properly.

Please follow the steps below:

- Open the box, press and hold the push button.
 - a. If the device triggers:
 - i. LED beacon` begin to emit blue and white lights
 - ii. The key box will open and provide access to the key or combination located inside.
 - b. If the device does not trigger, contact the Innovation Lab.
- Ensure key box closes correctly when reengaging the device.

Troubleshooting

What to do if system fails

- Include checklist and common errors.

When to Contact iLab

- Provide iLab contact details (email/phone/location).

Test Button – there is a bright red button that is labeled “PUSHBUTTON” on the circuit board. If you push and hold it, the device will trigger.

Arduino Code

Contact the Innovation Lab if you would like a copy of the Arduino code. There are 2 files, one when the device has access to Wi-Fi and another when there is no access. The code logs the acceleration data every second and creates a running average, then it reads over that average and checks if it is over a specified threshold. If the acceleration goes over that threshold for a specified number of seconds, the device will trigger the solenoid, turn on the LED, and send an email if applicable. This threshold is variable based on the user's desire to trigger the device via a certain magnitude earthquake.

3D Files

Contact the Innovation Lab if you would like a copy of the 3D printed files used for the Key Box. The preferred filament to be used should be PC - Poly Carbonate. Other filaments such as PETG or PLA may cause issues with engaging and disengaging the solenoid and "door".

Bill of Materials

Item	Price (\$)	Quantity
Adafruit Feather Huzzah with ESP8266	14.95	1
AC/DC ADAPTER 12V 1A - 839-1671-ND	8.07	1
STL LED 360° Warning Light	40.00	1
Or STL LED Beacon	139.99	1
Solenoid - 1528-5135-ND	7.50	1
Pololu MinIMU-9 v6 Gyro, Accelerometer, and Compass	26.85	1
Push Button - TS02-66-50-BK-160-LCR-D	0.10	1
IRLB8721 FET	1.48	2
Buck Converter - 1951-TSR1.5-2450E-ND	6.16	1
Diode - 4878-1N4001CT-ND	0.11	1
10k-ohm Resistor	0.10	2
10-ohm Resistor	0.10	2
3.6-ohm Resistor	0.10	1
3.3k-ohm Resistor	0.10	1
Male and Female 2 pin headers	2.00	3
USB DIY Slim Connector Shell - MicroB Plug	0.95	1
Weatherproof Electrical Box	18.88	1
Small padlock with key	5.00	1
3D printed Housing		1
Misc. wires and heat shrink	5.00	N/A
Total:	\$143.13	22

